

CHAPTER 12: OFF-STREET PARKING AND LOADING

6-12-1 GENERAL PROVISIONS

The provisions of this Chapter shall apply as follows:

A. Existing Facilities

1. Existing off-street parking and loading facilities shall not be reduced below the requirements of this Chapter. If such existing facilities are already less than the requirements of this Chapter they shall not be further reduced.
2. Existing off-street parking and loading facilities which do not conform to the requirements of this Chapter, but were in conformance with the requirements of this Ordinance at the time the parking or loading facilities were established, are permitted to continue as legal nonconforming uses.
3. Where a building permit has been issued prior to the effective date of this Ordinance, and provided that construction is commenced within one hundred and eighty (180) days of such date and diligently pursued to completion, parking and loading facilities shall be provided in the amounts required for the issuance of said building permit, regardless of the amount required by this Chapter.

B. Damage or Destruction

When a building is reconstructed or repaired after being damaged or destroyed by over fifty percent (50%), off-street parking and loading facilities shall be restored in conformance with the requirements of this Ordinance. However, it shall not be necessary to restore or maintain parking and loading facilities in excess of the applicable requirements of this Chapter.

C. Change in Land Use

When an existing use of a building, structure or parcel of land is changed to a new use, parking and loading spaces shall be provided as required for such new use. Additional parking or loading spaces shall be required in the amount by which the requirements for the new use exceed the requirements for the existing use.

D. Change in Intensity of Use

1. When the intensity of use of any building, structure, or parcel of land is increased, additional parking and loading spaces shall be provided. The number of additional parking and loading spaces shall be based on the increase in the number of dwelling units, gross floor area, seating capacity, or other unit of measurement used to calculate the number of required number of parking or loading spaces.
2. When the intensity of use of any building, structure, or parcel of land is decreased, the number of parking and loading spaces may be reduced so long as the parking requirements of this Chapter are met for the entire building, structure, or parcel of land as modified.

E. Provision of Additional Spaces

Nothing in this Chapter shall be deemed to prevent the voluntary establishment of off-street parking or loading facilities, provided that all regulations governing the location, design, and control of such facilities shall be in accordance with this Chapter.

F. Limitations on Use

No motor vehicle repair or cleaning of any kind shall be permitted in any parking space, parking lot, or loading berth. No gasoline, motor oil, or any other accessory or similar product shall be sold or dispensed in such areas.

6-12-2 COMPUTATION

The total number of required parking and loading spaces shall be based upon the requirements for the principal use of the lot. However, when more than one (1) use occupies the same lot, the number of required spaces shall be the sum of the separate requirements for each use. All off-street parking facilities shall be completed before occupancy of the building or structure served. In computing the number of off-street parking or loading spaces required by this Chapter, the following standards for computation shall apply:

- A.** Space allocated to any off-street loading space shall not be used to satisfy the requirement for any off-street parking space or access aisle, or portion thereof. Conversely, the area allocated to any off-street parking space shall not be used to satisfy the replacement for any off-street loading space or portion thereof.
- B.** A fraction of less than one-half ($\frac{1}{2}$) may be disregarded and a fraction of one-half ($\frac{1}{2}$) or more shall be counted as one (1) parking or loading space.
- C.** In places of assembly in which patrons or spectators occupy benches, pews, or similar seating facilities, each twenty-four (24) inches of such seating facility shall be counted as one (1) seat for the purpose of determining the requirement for off-street parking facilities.
- D.** Except as otherwise specified, parking or loading spaces required on an employee basis shall be based on the maximum number of employees normally present on the premises at any one time. When the determination of the number of parking spaces is based on the number of employees, the owner and/or manager shall be counted as an employee(s).
- E.** For commercial and industrial uses, where there is accessory office space that serves the administrative functions for a commercial or industrial use, this floor area shall be included in the gross floor area calculation for the principal use, rather than be used to calculate the requirement separately for office space. The exception shall be that any floor area devoted to office space that exceeds three percent (3%) of the gross floor area shall be required to meet the parking requirement for professional office space.

6-12-3 CONSTRUCTION OF PARKING AND LOADING FACILITIES**A. Site Plan Review Required**

Site plan review, in accordance with Section 6-4-5 (Site Plan Review), is required prior to any construction, alteration or addition of any parking facility providing four (4) or more parking spaces, and for any loading facility. For purposes of this Section, construction, alteration or addition shall include all paving of previously unpaved surfaces, replacement of pavement with new binder and surface courses, construction of curbing, installation of

new parking lot landscaping, and similar activities. Construction, alteration or addition shall not include maintenance activities such as replacement of existing landscaping, repair of existing curbing, repairs, sealing, re-striping, or placement of surface course pavement over previously paved areas. No permit shall be required for maintenance activities.

B. Time of Completion

Off-street parking and loading facilities required by this Chapter shall be completed prior to the issuance of the occupancy permit for the use they serve. If weather conditions do not permit such completion, the Building Commissioner may issue a temporary occupancy permit in accordance with the requirements of Section 6-4-7 (Occupancy Permit).

6-12-4 COLLECTIVE PROVISIONS

Off-street parking spaces for separate uses may be provided collectively if the aggregate number of spaces provided is not less than the sum of the spaces required for each use separately. No parking or loading space, or portion thereof, shall serve as the required space for more than one (1) use.

6-12-5 SHARED PARKING

An off-street parking facility may be shared between two (2) or more uses, provided that use of such facility by each user does not occur at the same time. No shared use of parking spaces shall be permitted unless:

- A.** The users of the shared parking facility shall sign an agreement, approved by the Village Attorney, expressing the intent to share parking facilities and shall file this agreement with the Village.
- B.** Approval is obtained from the Building Commissioner that confirms that the use of such facility by each user does not take place at the same hours during the same days of the week.
- C.** The location and design requirements of this Chapter are met.
- D.** Any subsequent change in ownership or use shall require proof that the minimum parking requirements, per this Chapter, have been met for each use. The owner of a building or use shall have one-hundred eighty (180) days within which to accommodate all required off-street parking or to apply for a variation. If the owner is unable to accommodate the parking or fails to apply for a variation, then the occupancy permit shall be revoked with respect to the building or use for which the separate parking was required. The occupancy permit shall be reinstated when all applicable provisions of this Chapter are complied with. As an alternative to a variation, a new shared parking agreement may be arranged in accordance with this Section.

6-12-6 LOCATION OF OFF-STREET PARKING SPACES

- A.** All required parking spaces for residential uses shall be located on the same lot as the building or use served. No parking is allowed in any required yard except in the following cases:
 - 1.** Parking shall be permitted in driveways. No such parking may encroach onto the public right-of-way.

2. Parking for three-unit or multi-unit dwellings in the R3 and R4 Districts may be located within (i.e., may encroach into) the required rear yard but is subject to site plan review in accordance with Section 6-4-5 (Site Plan Review).
- B. All required parking for non-residential uses shall be located on the same lot as, or within six hundred (600) feet walking distance of, the building or use served. However, off-street parking accessory to a non-residential use shall not be located in a residential zoning district.
 - C. In the C1 and C2 Districts, off-street parking lots are not permitted at the front of the property (front lot line).

6-12-7 OWNERSHIP AND CONTROL

Where parking facilities are located on a lot separate from the building or use served, the owner of the lot containing the building or use shall demonstrate the right to maintain and use such parking by either of the following:

1. The lot containing the building or use served and the lot containing the parking shall have the same owner of record.
2. The owner of record of the lot containing the building or use served shall have a recorded lease for the lot containing the parking.

If the owner of a building or use no longer has the right to maintain or use parking facilities on a separate lot (for example, when a lease expires and is not renewed), the owner of a building or use shall have one-hundred eighty (180) days within which to accommodate all required off-street parking or to apply for a variation. If the owner is unable to accommodate the parking or fails to apply for a variation, then the occupancy permit shall be revoked with respect to the building or use for which the separate parking was required. The occupancy permit shall be reinstated when all applicable provisions of this Chapter are complied with.

6-12-8 DESIGN OF OFF-STREET PARKING SPACES

All off-street parking facilities shall comply with the following standards:

A. Dimensions

Off-street parking spaces shall be at least eight and one-half (8.5) feet in width and eighteen (18) feet in length. Parking spaces shall have a minimum vertical clearance of seven (7) feet. See Figure 8: Parking Space Dimensions.

FIGURE 8: PARKING SPACE DIMENSIONS

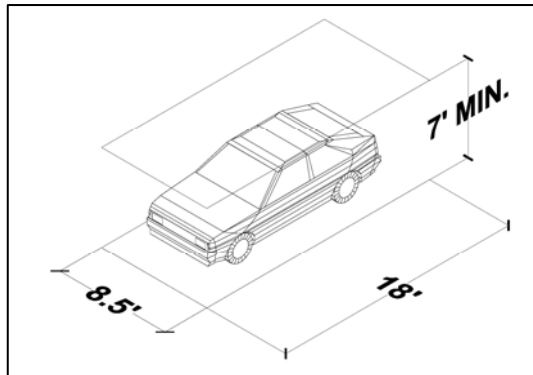

B. Access

1. Each off-street space shall open directly upon an aisle or driveway of such width as will provide adequate means of vehicular access to such parking space. All off-street parking facilities shall be provided with appropriate means of vehicular access in a manner that least interferes with traffic movement and allows the driver of the vehicle to proceed forward into traffic rather than back out.
2. All required off-street parking facilities shall have vehicular access from a street, alley, driveway or cross-access connection. Within off-street parking facilities one-way traffic aisles shall be at least sixteen (16) feet in width and two-way traffic aisles shall be at least twenty-four (24) feet in width.

3. Driveways

a. Residential Driveways, Excluding Multi-Unit

- i. A residential driveway that provides access to a detached garage shall be no more than twelve (12) feet in width. A driveway apron, the width of the garage as measured from the garage walls, is permitted to extend for a distance (depth) of twenty (20) feet from the garage doors before tapering back to the required driveway width to allow access to the additional spaces. See [Figure 9: Detached Driveway Width](#).

FIGURE 9: DETACHED DRIVEWAY WIDTH

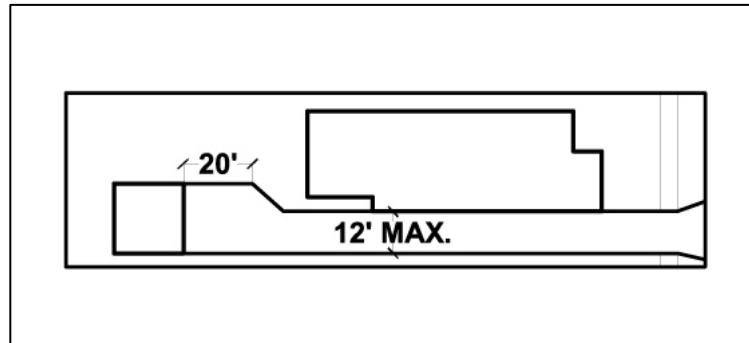

- ii. A residential driveway that provides access to an attached garage shall be no wider than the width of the garage. See [Figure 10: Attached Driveway Width](#).

FIGURE 10: ATTACHED DRIVEWAY WIDTH

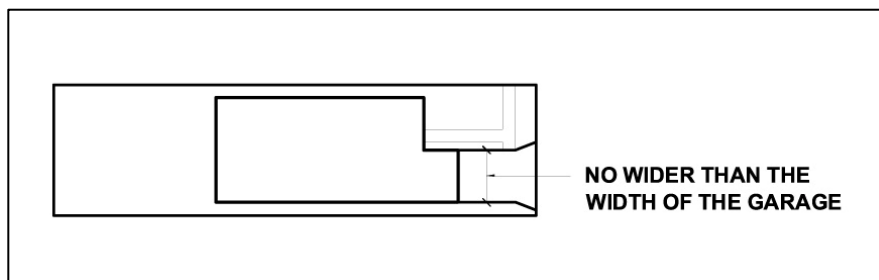

- iii. Residential driveways must lead to garage access and must comply with width standards as described above. In cases where a parking area, whether enclosed (garage) or unenclosed (parking pad), is located in the rear of a lot, a driveway may lead to the rear of a lot to access that parking area. In such cases, the driveway width must comply with Paragraph i above. In no case shall a driveway be installed that does not lead to a parking area.

b. Multi-Unit and Non-Residential Driveways

Except for access to loading berths, no driveway across public property shall have a width exceeding twenty four (24) feet.

C. Surfacing

All open off-street parking areas shall be improved with a hard surfaced, all-weather dustless material as approved by the Village Engineer. Semi-pervious materials such as grass-crete and brick pavers may also be used, subject to the approval of the Village Engineer.

D. Striping

Parking lots of four (4) or more spaces shall delineate parking spaces with paint or other permanent materials, which shall be maintained in clearly visible condition. Parking spaces for handicapped persons shall be identified with the appropriate sign and shall be visible at all times of the year, regardless of snow cover, plant growth, or similar conditions.

E. Curbing and Bumper Stops

Bumper stops, wheel stops, or curbing shall be provided to prevent vehicles from damaging or encroaching upon any adjacent parking or loading space, sidewalk, landscaped area or parking lot island, fence, wall, or building. Curbing shall be at least six (6) inches in height. Regardless of bumper stops or wheel stops, the length of the parking stall shall be eighteen (18) feet.

F. Slope

Except for parking spaces accessory to a single-unit detached dwelling, no area of any parking facility shall have a slope of more than five percent (5%). No access ramp shall have a slope of more than eight percent (8%).

G. Lighting

Parking lot lighting shall be in accordance with Section 6-11-2 (Exterior Lighting). Illumination of an off-street parking area shall be arranged so as to deflect the direct rays of light away from adjacent properties and streets.

H. Landscaping

All parking lots shall be landscaped in accordance with Chapter 14: Landscaping and Screening.

6-12-9 ACCESSIBLE PARKING

A. Required Spaces

In all off-street parking facilities where parking is provided for employees, visitors, or both, parking spaces for disabled persons shall be provided. The number of accessible parking spaces shall be included in the total number of required parking spaces and shall be in accordance with the applicable requirements of the Illinois Accessibility Code, as amended from time to time, and all additional governing codes and applicable laws.

B. Dimensions and Design

Such spaces shall comply with the design standards presented in the State of Illinois Accessibility Code, provided that in no instance shall the width of any one (1) space be less than sixteen (16) feet. Such spaces shall be identified by a sign and pavement markings indicating parking for the disabled only. Such spaces shall be the spaces closest to the entrance of the building or structure, and shall be connected by a paved surface designed to provide safe and easy access.

6-12-10 STACKING SPACES FOR DRIVE-THROUGH FACILITIES

A. Design

Stacking spaces provided for drive-through uses shall be:

1. A minimum of nine (9) feet in width, as measured from any service window to the edge of the driveway, and eighteen (18) feet in length. See Figures 11: Stacking Space Design and Figure 12: Drive-Aisle Width.
2. Placed in a single line behind the drive-through facility.
3. Located so that, when in use, they do not obstruct ingress/egress to the site and do not obstruct access to required parking or loading spaces.
4. For a car wash, stacking spaces shall begin behind the last vehicle being washed. For all other drive-in uses, stacking spaces shall begin behind the vehicle parked at a last point of service, such as a window.

FIGURE 11: STACKING SPACE DESIGN

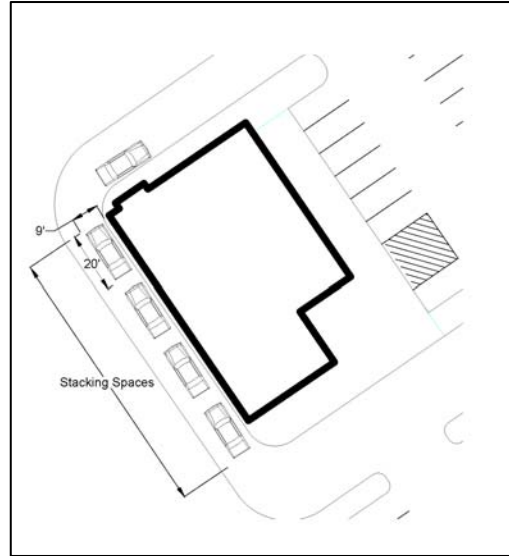
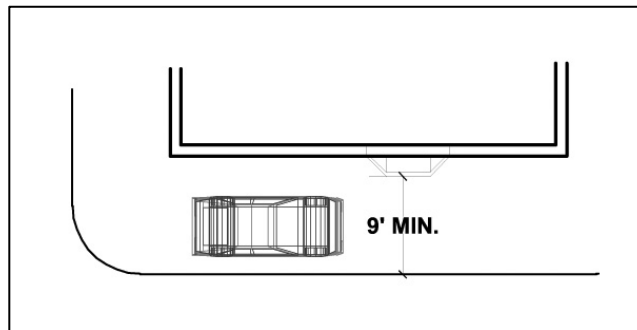

FIGURE 12: DRIVE-AISLE WIDTH



B. Required Spaces

Every drive-through facility shall provide a minimum of three (3) stacking spaces per facility, unless otherwise required by Table 12: Required Off-Street Parking or this Ordinance.

C. Reduction of Required Spaces

The number of required stacking spaces may be reduced during the site plan review process if the petitioner presents a study with quantifiable evidence (e.g., comparable information) which demonstrates that a different requirement should be imposed. The approval of a reduced number of stacking spaces shall apply only to the specific business for which the study was conducted.

6-12-11 COMMERCIAL VEHICLES IN RESIDENTIAL DISTRICTS

The following restrictions shall apply to the parking or storage of commercial vehicles on property zoned for residential use.

- A. No commercial vehicle shall be parked on any public right-of-way in a residential district, except for vehicles engaged in loading or unloading, or vehicles in connection with current work being done to the adjacent premises.
- B. No stored or parked commercial vehicle shall be occupied or used for human habitation.
- C. Only standard-sized, passenger vehicles including, but not limited to, automobiles, vans, sports utility vehicles (SUVs) and pick-up trucks are permitted to be stored or parked outdoors overnight on residentially-zoned private property.
- D. Permitted commercial vehicles, as described in Paragraph C above, shall include such vehicles that are owned and used for commercial purposes by the occupant of a dwelling or guest, provided that the vehicle is stored or parked in the permitted parking area; such permitted commercial vehicles may include the logo of the commercial business painted on or applied to the vehicle. All other commercial vehicles including, but not limited to, semi-truck tractor units, with or without attached trailers, commercial trailers, buses, limousines, tow trucks, construction vehicles or other large commercial or livery vehicles required to register for a "C-plate" in Illinois or other classification for commercial vehicles, are not permitted to be stored or parked outside overnight on residentially-zoned property.

6-12-12 RECREATIONAL VEHICLES IN RESIDENTIAL DISTRICTS

For the purposes of this Section, recreational vehicles shall include all trailers, campers, motor homes, boats, pop-up campers, and trailers that transport snowmobiles, wave-runners, ATVs, etc.

- A. No recreational vehicle or trailer licensed to transport recreational vehicles or equipment shall be parked in the public right-of-way in or in the driveway of a residential district for more than forty-eight (48) hours.
- B. Recreational vehicles may be parked or stored in any zoning district only when located in a fully enclosed permanent structure or completely screened from view by a solid wood fence, masonry screen wall or slatted chain link fence at least six (6) feet in height. Temporary storage tents for recreational vehicles shall not be considered such a structure.
- C. No recreational vehicle shall be used for living, sleeping, or housekeeping purposes in any zoning district.
- D. This Section does not apply to recreational vehicles offered for-sale in an approved outdoor sales and display area of a motor vehicle dealership.

6-12-13 REQUIRED OFF-STREET PARKING SPACES

- A. The minimum number of off-street parking spaces to be provided for the designated uses shall be as follows in Table 12: Requirements for Off-Street Parking. Table 12 lists parking requirements for the generic uses listed within the districts. In some cases, uses which are considered part of a generic use category are listed with specified parking requirements. These specific uses are listed only for the purposes of this Section and do not indicate whether such uses are permitted or special uses within any district. Certain generic uses listed within the districts do not have parking requirements. These types of uses are not listed within Table 12.
- B. Businesses under one-thousand (1,000) square feet in gross floor area in the R4, C1 and C2 Districts are exempt from the parking requirements of Table 12. Only those

businesses within the following use categories of [Table 12](#) are exempt: cultural and religious uses, recreational and entertainment uses, and retail and service uses. Those businesses under one-thousand (1,000) square feet in gross floor area located within a shopping center configuration (i.e., a “strip mall”) shall not be eligible for this exemption and must provide the required parking.

- C. In the R4, C1 and C2 Districts, on-street/on-right-of-way parking spaces that are located along the front or side property line may be counted toward required off-street parking spaces. New on-street/on-right-of-way parking spaces may be created to count toward required off-street parking but must be located along the side or front property line, must be accessible twenty-four (24) hours a day and must provide a sidewalk a minimum of five (5) feet in width for public access. See [Figure 13: On-Right-of-Way Parking](#). At least fifty percent (50%) of the width of an on-street space must be located along the property line of the property under consideration in order to count toward off-street parking requirements. See [Figure 14: On-Right-of-Way Parking Space Consideration Standard](#).

FIGURE 13: ON-RIGHT-OF-WAY PARKING

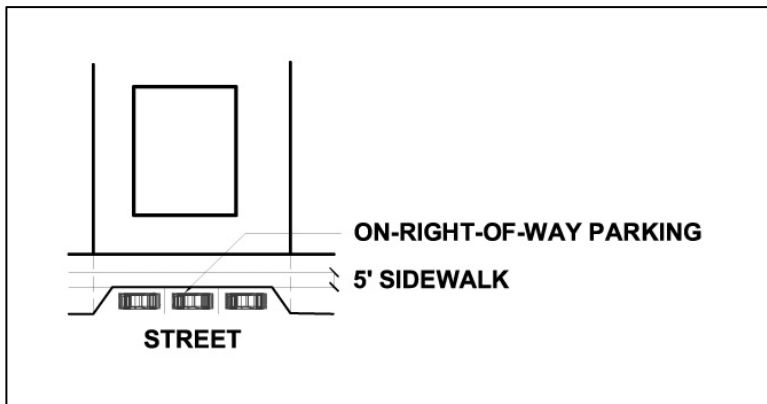

FIGURE 14: ON-RIGHT-OF-WAY PARKING SPACE CONSIDERATION STANDARD

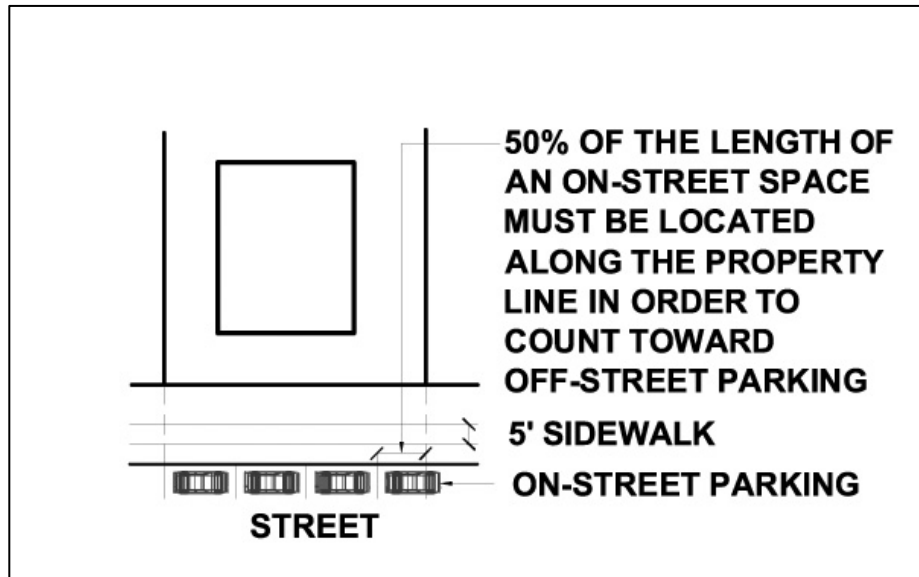

TABLE 12: REQUIRED OFF-STREET PARKING	
USE	PARKING REQUIREMENT
RESIDENTIAL USES	
Dwelling, Multi-Unit	1- or 2-bedroom dwelling unit: 1.5 per dwelling unit 3-bedroom or more dwelling unit: 2 per dwelling unit
Dwelling, Single-Unit	2 per dwelling unit, maximum of 4 spaces
Dwelling, Townhouse	2 per dwelling unit
Dwelling, Three-Unit	5 spaces
Dwelling, Two-Unit	3 spaces
Group Home	.25 per bed + 1 per 2 employees
Live/Work Dwelling	2 per dwelling unit
CULTURAL AND RELIGIOUS USES	
Art Gallery	2 per 1,000sf of gross floor area
Convent/Monastery	1 per 1,000sf of residential living area
Cultural Facility	4 per 1,000sf of gross floor area
Place of Worship	1 per 4 seats of maximum seating capacity
RECREATIONAL AND ENTERTAINMENT USES	
Club or Lodge	3 per 1,000sf of gross floor area
Indoor Entertainment	4 per 1,000sf of public use area
<i>Movie Theater</i>	<i>1 per 4 seats for first 400 seats + 1 per 6 additional seats</i>
Indoor Recreation	4 per 1,000sf of public use area
<i>Bowling Alley</i>	<i>2 per lane</i>
<i>Pool Hall</i>	<i>1 per table</i>
Live Entertainment	4 per 1,000sf of public use area
Outdoor Entertainment	2 per 1,000sf of public use area
Outdoor Recreation	2 per 1,000sf of public use area
GOVERNMENT AND EDUCATIONAL USES	
Educational Facilities, College/University	To be determined by the Planning and Zoning Administrator
Educational Facilities, Primary/Secondary	To be determined by the Planning and Zoning Administrator
Educational Facilities, Vocational School	To be determined by the Planning and Zoning Administrator
Government Facility	To be determined by the Planning and Zoning Administrator
Public Safety Facility	To be determined by the Planning and Zoning Administrator
Public Works Facility	To be determined by the Planning and Zoning Administrator
RETAIL AND SERVICE USES	
Animal Hospital	1 per full-time employee + 1 per 30sf of waiting room area
Assisted Living Facility	.25 per bed + 1 per 2 employees
Car Wash	1 per 2 employees + stacking spaces in accordance with Section 6-12-10
Currency Exchange	4 per 1,000sf of gross floor area
Day Care Center, Adult or Child	1 per 2 employees + 2 passenger loading spaces
Financial Institution	3 per 1,000sf of gross floor area + stacking spaces in accordance with Section 6-12-10 for drive-through banking facilities
Gas Station	2 per 1,000sf of gross floor area of any accessory convenience retail and/or food service + stacking spaces in accordance with Section 6-12-10 for accessory automatic car wash
Greenhouse/Nursery	1 per 1,000sf of gross floor area of building + 2 per 1,000sf of outdoor sales & display area
Heavy Retail and Service	4 per 1,000sf of gross floor area, including outdoor sales & display area

TABLE 12: REQUIRED OFF-STREET PARKING	
USE	PARKING REQUIREMENT
Hospital	100 beds or less: 1 per bed 101 to 300 beds: 1.1 per bed 301 to 500 beds: 1.2 per bed 500 beds or more: 1.3 per bed
Hotel/Motel	1.25 per room
Independent Living Facility	.5 per dwelling unit + 1 per 2 employees
Kennel	1 per 1,000sf of GFA + 1 per 4 pet owners if animal training classes are taught on-site (based on maximum class size)
Medical/Dental Clinic	1.5 per exam room
Motor Vehicle Dealership	1 per 1,000sf of sales & display area (indoor & outdoor)
Motor Vehicle Rental Establishment	1 per 1,000sf of display area (indoor & outdoor)
Motor Vehicle Service and Repair, Major or Minor	1 per 500sf of gross floor area
Nursing Home	.25 per bed + 1 per 2 employees
Office Business	4 per 1,000sf of gross floor area
Personal Services Establishment	2 per 1,000sf of gross floor area
Payday or Title Loan Agency	4 per 1,000sf of gross floor area
Restaurant	1 per 60sf of public seating area (include any outdoor dining area in public seating area)
Retail Goods Establishment	2 per 1,000sf of gross floor area
Tavern/Bar	1 per 60sf of public seating area
TRANSPORTATION USES	
Cargo Terminal	1 per 1,000sf of gross floor area
Motor Vehicle Operations Facility	1 per 1,000sf of gross floor area
Passenger Terminal	1 per 1,000sf of terminal area
MANUFACTURING, STORAGE AND RESEARCH USES	
Manufacturing, Light	3 per 1,000sf of gross floor area
Manufacturing, Medium	3 per 1,000sf of gross floor area
Mini-Warehouse	1 per 10 storage units
Research and Development Facility	4 per 1,000sf of gross floor area
Warehouse/Distribution	1 per 1,000sf of gross floor area
OPEN SPACE USES	
Cemetery	1 per 250sf of office and/or chapel space
Country Club	See applicable uses (golf course, driving range, restaurant, etc.)
Driving Range (Principle Use)	1 per tee
Golf Course	4 per hole
Zoo	1 per 1,000sf of gross floor area

6-12-14 REQUIRED OFF-STREET LOADING SPACES

Off-street loading spaces shall be provided for a building, structure, or use which requires the receipt or distribution of materials or merchandise by trucks or other vehicles larger than eighteen (18) feet in length, in accordance with Table 13: Off-Street Loading Requirements:

TABLE 13: OFF-STREET LOADING REQUIREMENTS	
Use Type	Number Of Spaces Required
Commercial, Office or Institutional Uses	
10,000 - 100,000sf of gross floor area	1 loading space
Each additional 100,000sf of gross floor area	1 loading space
Industrial	
5,000 - 10,000sf of gross floor area	1 loading space
10,001 - 40,000sf of gross floor area	2 loading spaces
40,001 - 100,000sf of gross floor area	3 loading spaces
For each additional 100,000sf of gross floor area over 100,001sf of gross floor area	1 loading space

6-12-15 DESIGN OF OFF-STREET LOADING SPACES

A. Location

1. All off-street loading spaces shall be located on the same lot as the building or use served and shall not project into a street or alley.
2. Off-street loading spaces shall be located at least twenty-five (25) feet from the intersection of any two (2) streets.
3. Off-street loading spaces shall not be located in any front or corner side yard.
4. All off-street loading spaces shall be located a minimum of fifty (50) feet from the lot line of any lot in a residential zoning district.

B. Dimensions

All required off-street loading spaces shall be at least twelve (12) feet in width and at least thirty (30) feet in length, exclusive of aisle and maneuvering space, and shall have a minimum vertical clearance of at least fifteen (15) feet.

C. Surfacing

All off-street loading spaces shall be improved with a compacted macadam base or equal not less than seven (7) inches thick, surfaced with not less than two (2) inches of asphaltic concrete or some comparable all-weather, dustless material, and subject to the approval of the Village Engineer

D. Access Control and Signage

Each required off-street loading space shall be designed with adequate means of vehicular access to a street or alley in a manner which will minimize interference with traffic movement and shall be subject to the approval of the Building Commissioner.

E. Lighting

Loading facility lighting shall be in accordance with Section 6-11-2 (Exterior Lighting). Illumination of an off-street loading facility shall be arranged so as to deflect the direct rays of light away from adjacent properties and streets.

F. Landscaping and Screening

All loading facilities shall be landscaped and screened in accordance with Chapter 14: Landscaping and Screening.